

WM3

LOW PROFILE STAGE MONITOR SYSTEM



- 15" Coax Neodymium Transducer in Vented Enclosure
- Modified exponential rotatable horn with controlled coverage
- Flying Mounting Points and Pole Mount Cup Included
- Powering Mode: Full-Range Passive
- For Portable Use or Permanent Installation

Product Information

2-WAY loudspeaker system is ideal for stage monitor applications high output vocal presence and neutral balanced sound. The 380 mm (15") low frequency cone with 76 mm (3") voice coil with Neodymium magnet and 75 mm (3") voice coil high frequency compression driver provides higher output and lower distortion plus enhanced power handling capabilities for better performance in both touring and permanently installed applications. LSS's advanced crossover includes professional protection of HF. The WM3 offers switchable powering mode: passive operation using the internal crossover filter network or Bi-Amp operation. WM3 is designed to support the widest possible range of pro audio applications. The pole mount cup provide front or side fill for touring applications.

Enclosure Material

- Enclosure Material: Birch Plywood of 18 mm
- Finish: Texture Polyurethane Black Paint
- Suspension: 6 Point Mounting Suspension
- Grille: Powder Coated Perforated Steel with anti-dust foam
- Connectors: 2 Neutrik NL4 Speakon
- Optional Accessories: Fly Clip with Ring, Flight Case for 2 WM3

INSTALL | EVENTS | PORTABLE | TOURING

Data Sheet

Frequency Response	±5 dB 50 Hz ~ 18 kHz -10 dB 40 Hz
Sensitivity (1 Watt @ 1 m) Max SPL Calculated	98 dB 126 dB
Nominal Input Impedance (Ω)	8 Ω
Power Handling (Watts Cont. AES) Peak Power	600 W 2400 W
Nominal Dispersion (@ -6 dB)	60°(V) x 40°(H) Rotable Horn
Dimensions mm (±1 mm) (H x W x D)	410 x 600 x 600
Weight	23 Kg

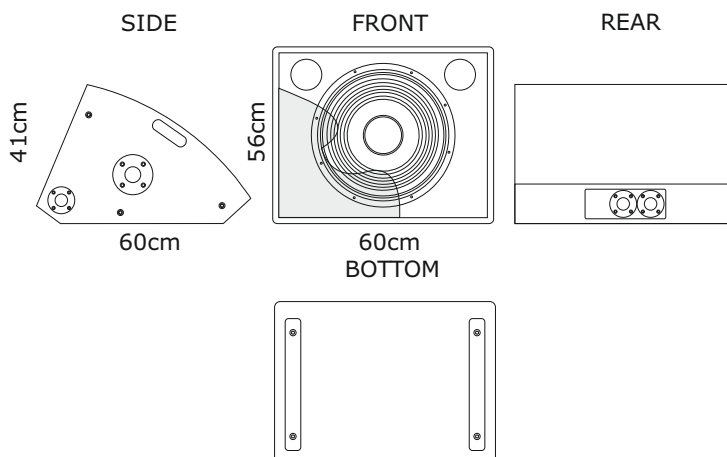

STAGE MONITORS

