



PROFESSIONAL AUDIO SYSTEM

# SB17



OPERATING MANUAL

Ver. SB17-EN-1.0

**LSS Advanced Speaker Systems**

Via On. Longo 53-89024 Polistena (RC) ITALY Tel (39) 966 9321299 – Fax (39) 966 933007 Email: info@lss.it - Internet: www.lss.it

## **NOTICE:**

LSS products are manufactured for use according to proper procedures by a qualified operator and only for the purposes described in this manual. The following conventions are used to indicate and classify precautions in this manual. Always heed the information provided with them. Failure to heed precautions can result in injury to people or damage to property.

## **© LSS, 2014**

All rights reserved. No part of this publication may be reproduced, stored in a retrieval system, or transmitted, in any form, or by any means, mechanical, electronic, photocopying, recording, or otherwise, without the prior written permission of LSS.

No patent liability is assumed with respect to the use of the information contained herein. Moreover, because LSS is constantly striving to improve its high-quality products, the information contained in this manual is subject to change without notice. Every precaution has been taken in the preparation of this manual. Nevertheless, LSS assumes no responsibility for errors or omissions. Neither is any liability assumed for damages resulting from the use of the information contained in this publication.

---

## SUMMARY

INTRODUCTION .....	4
SAFETY AND WARNING.....	5
CONTROLS AND INSPECTIONS .....	6
APPLICATION.....	7
PHYSICAL DESCRIPTION.....	7
TECHNICAL SPECIFICATIONS .....	8
INSTALLATION AND WIRING .....	9
MOUNTING THE ARRAY .....	10
INSTALLATION ON BUMPER .....	14
BUMPER AND SYSTEM HANGING .....	15
ARRAY SIMULATOR SOFTWARE .....	16
INSTALLATION ON A POLE .....	17
TRANSPORT OF SPEAKERS .....	18
ELECTRICAL CONNECTION.....	19
WEEE DIRECTIVE .....	21
DIMENSIONS.....	22
NOTES .....	23

## INTRODUCTION

Congratulation on the purchase of your new LSS loudspeaker. Quality innovation and versatility, this is a summary of the new system developed by LSS for professional sound users. LSS produces professional audio products – the result of exceptional engineering and meticulous craftsmanship. This manual is intended for use with LSS loudspeaker. This includes: safety precautions; installation, set-up and operating instruction. Please read this manual plus any accompanying manual and follow all relevant precautions and instructions. This should allow you to obtain the maximum performance from your new loudspeaker. Where there are conflicts or overlaps, the information in any accompanying manual supersedes the information in this manual.

## SAFETY AND WARNING

### IMPORTANT! SAFETY WARNING!

In the interest of their own and others' safety and to prevent voiding the warranty, we recommend a careful reading of this section before using the product.

- This product was designed and manufactured to be used as a speaker system in the context of a typical sound reinforcement system.

The use for any purpose other than these is not provided by the manufacturer and is therefore under the direct responsibility of the user / installer.

- This device complies with class I (must be connected to the outlet with a protective earthing connection).



#### WARNING

RISK OF ELECTRIC SHOCK  
DO NOT OPEN

TO REDUCE THE RISK OF ELECTRIC SHOCK  
DO NOT REMOVE COVER (OR BACK)  
NO USER SERVICEABLE PARTS INSIDE  
REFER SERVICING TO QUALIFIED SERVICE PERSONNEL  
TO REDUCE THE RISK OF FIRE OR ELECTRIC SHOCK  
DO NOT EXPOSE THIS EQUIPMENT TO RAIN OR MOISTURE

### TO AVOID THE RISK OF FIRE AND / OR ELECTRIC SHOCK\*:

- Do not expose this system to rain or moisture. Do not expose the apparatus to dripping or splashing water. Do not place objects filled with liquids, such as drinks, on the apparatus.

- Before connecting the system, be sure the mains voltage corresponds to that stated on the product.

- Connect this appliance to a power outlet with earth contact, according to national security force, via a power cable of adequate section with a plug or connector that meets the applicable safety regulations.

- The unit is connected to the network even when the power switch is in position '0' (OFF). Before any maintenance, disconnect the power cable from the outlet.

\*Risk of electric shock only for self-powered system.

### IMPORTANT! SAFETY PRECAUTIONS!

Read This First.

Read and heed all warnings and safety instructions in this Manual before using the product.

Failure to follow all precautions can result in equipment damage and / or personal injury.

1. Read these instructions.
2. Keep these instructions
3. Heed all warnings and follow all instructions.
4. Use only attachments/accessories specified by the manufacturer.
5. Use only with the cart, stand, tripod, bracket, or table specified by the manufacturer, or sold with the apparatus. When a cart is used, use caution when moving the cart/apparatus combination to avoid injury from tip-over.
6. Refer all servicing to qualified service personnel. Servicing is required when the apparatus has been damaged in any way, such as power-supply cord or plug is damaged, liquid has been spilled or objects have fallen into the apparatus, the apparatus has been exposed to rain or moisture, does not operate normally, or has been dropped.
7. LSS loudspeakers can produce sound levels capable of causing permanent hearing damage from prolonged exposure. The higher the sound level, the less exposure needed to cause such damage

CAUTION: This product is energized as long as it is connected to the AC.

CAUTION: Allow at least six inches of free space all around the amplifier for sufficient ventilation.

## CONTROLS AND INSPECTIONS

This chapter contains important information about precautions to be taken about the suspension of a LSS line-array system.

Before proceeding with any operation for lifting the system, therefore recommend that you read this chapter and follow the tips and warnings it contains. The lifting of a line-array system must be made only by personnel familiar with proper preparation, experience and knowledge of the applicable safety standards.

The flow rates of suspension accessories provided by LSS are certified by a qualified consultant external to the Company.

The original document is available at the LSS office.

You must regularly inspect the facility and, in case of doubt, immediately replace all the material and all equipment used for the suspension.

This practice is essential to prevent damage to property and or person: no way you can overlook this rule and proceed by accepting a risk.

We strongly recommend, therefore, to follow a regular program of checks and inspections on all components, which must be documented by inspection reports compiled by the staff that has installed the system.

In case of accident, local codes may require proof documentation of audit reports and the corrective action in place following the detection of defects.

In some countries (including Italy) rules on the maintenance of lifting equipment (hoists, ropes and chains) require periodic checks and inspections carried out by a company or by licensed professionals.

It is absolutely not permissible to accept the risks with regard to safety of public or staff!

When you suspend a system to support structures on the ceiling or roof, it must be ensured with extreme care, by calculation or, in some cases, by instrumental measurements, which do not exceed the maximum flow rate of the structures themselves in order the installation is absolutely secure.

Do not install speakers or entire systems to unsafe structures. If necessary, consult licensed professional.

All suspension accessories NOT provided by LSS are under the responsibility of the user, that uses them at his own risk and peril.

## APPLICATION

SB17 is an extension module for low-frequency reinforcement of line array ST17. It is ideal for creating a vertical array systems with a ratio of one sub with two ST17. SB17 can be used as main system in the wider range of professional audio applications. The ultra-compact design is intended to fulfil the highest demands of audio professionals and delivers the ultimate performance level in its category and meets the demands of both the fixed installation and rental production markets. SB17 is the ideal complement to the ST17 to extend the response up to 150 Hz. SB17 is extremely lightweight and compact and virtually invisible the integrated rigging system, combines extremely quick set up and system integration with significant savings on storage and handling logistics. ST17 and SB17 are ideal with rigging limitations in theatres, performing art centres, concert halls, convention centres, sport facilities, and TV/Broadcast studios, with the added bonus of being stealth philosophy.

## PHYSICAL DESCRIPTION

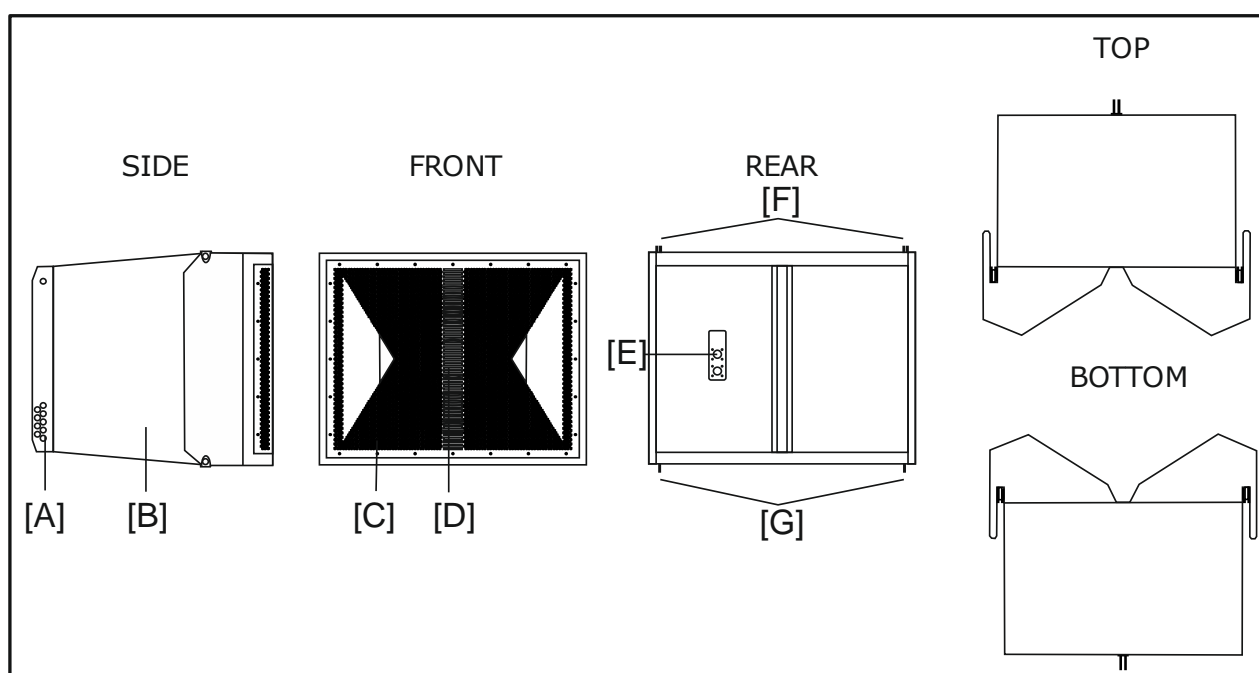

- [A] Rear brackets
- [B] Enclosure Cabinet
- [C] Steel protection grid
- [D] Woofer

- [E] Connection panel
- [F] Top Fixing brackets
- [G] Bottom Fixing brackets

Materials and construction meet the highest professional standards to ensure maximum reliability

## TECHNICAL SPECIFICATIONS

<b>PHYSICAL</b>	<b>Dimensions mm (<math>\pm 1</math> mm) [Inches]</b>	Width 580 [22.83"]
		Front Height 460 [18.11"]
		Rear Height 405 [15.94"]
		Depth 476 [18.74"]
		Trapezoid Angle (degrees) 4.5° per side
	<b>Weight Kilograms</b>	Net Weight 25 Shipping Weight 29
<b>SYSTEM PERFORMANCE</b>	<b>Frequency Response</b>	$\pm 3$ dB 40 Hz ~ 150 Hz -10 dB 35 Hz
	<b>Sensitivity (1 Watt @ 1 m)</b>	98 dB
	<b>Max SPL Calculated</b>	126 dB
	<b>Nominal Input Impedance (<math>\Omega</math>)</b>	8 $\Omega$
	<b>Power Handling (Watt cont. AES)</b>	700 W
	<b>Peak Power (W)</b>	2800W
	<b>Nominal Dispersion (@ -6 dB)</b>	360°
<b>MECHANICAL</b>	<b>Enclosure material</b>	Birch Plywood of 15 mm [0.59 inches]
	<b>Finish</b>	Texture poliurethanic black paint
	<b>Grille</b>	Powder coated perforated steel with anti dust foam
	<b>Connectors</b>	2 Neutrik NL4 Speakon
	<b>Accessories</b>	Flight Case for 2 SB17 (optional), Pole mount cup, coupling and suspension hardware (included)



## INSTALLATION AND WIRING

SB17 is an extension module for low-frequency reinforcement of line array ST17 and can be used both in flying or stacking configuration.

ST17 and SB17 have the same mounting hardware and similar shape in order to facilitate the creation of arrays.

Maximum number of speakers in Flying configuration is 16

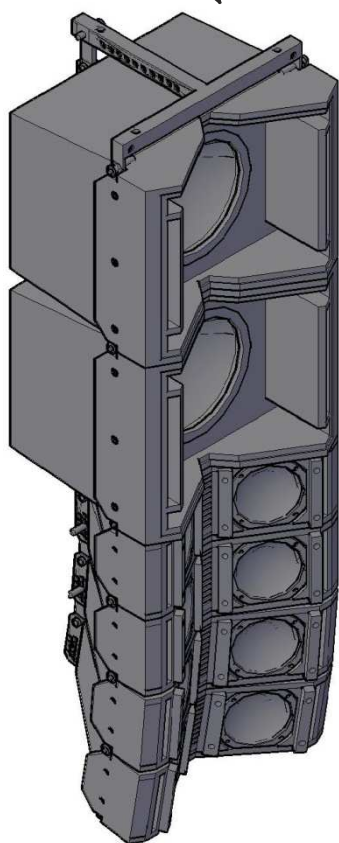

Maximum number of speakers in Stacking configuration is 4

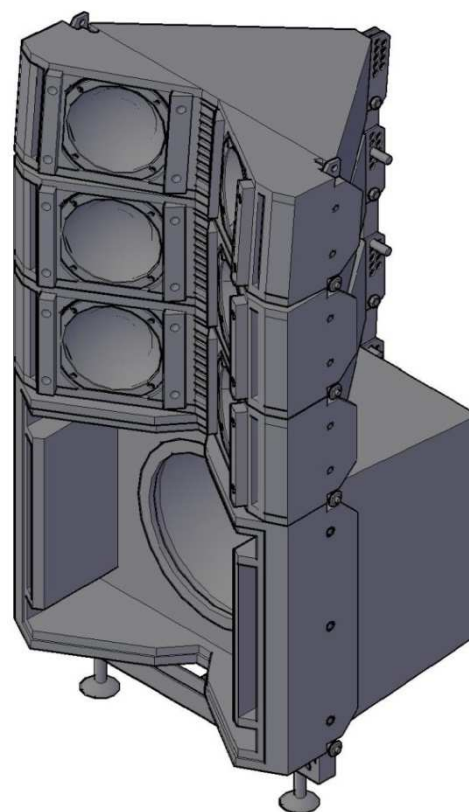

It is preferable to install one sub every two speakers.

## MOUNTING THE ARRAY

Each loudspeaker has a hardware that allows to be connected and secured to the other loudspeaker.

Hardware consist of three points System; two in the front side (Rigging Holes) used to lock the speaker, and one in the rear (Bracket) used to regulate the tilt.

Specular points are used to hook another speaker in order to create an array.

Rigging holes are in the top and in the bottom of the case:

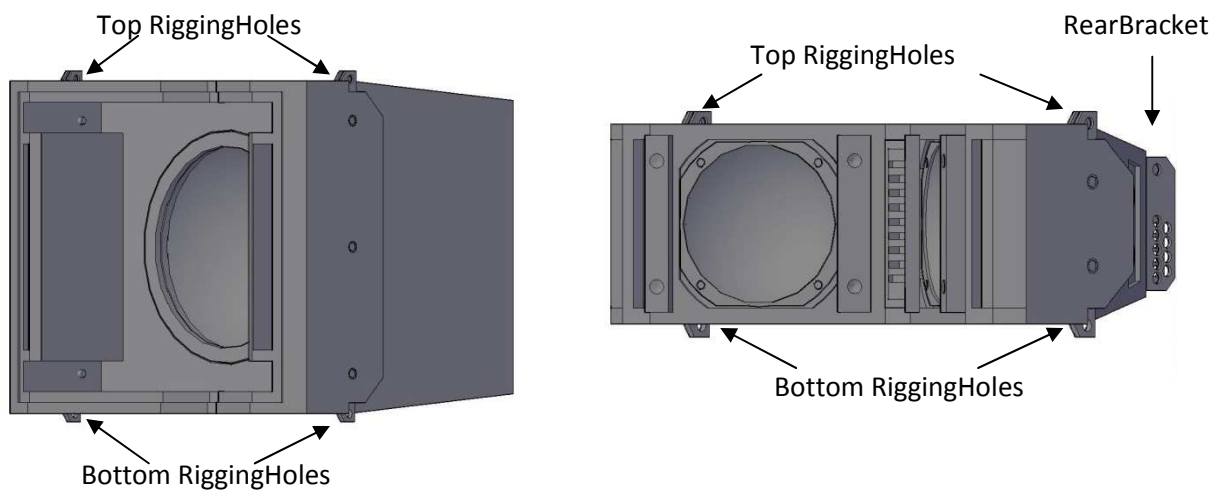

The bracket with rigging holes has a female side and a male side in order to facilitate the snap-in mounting of more speakers.

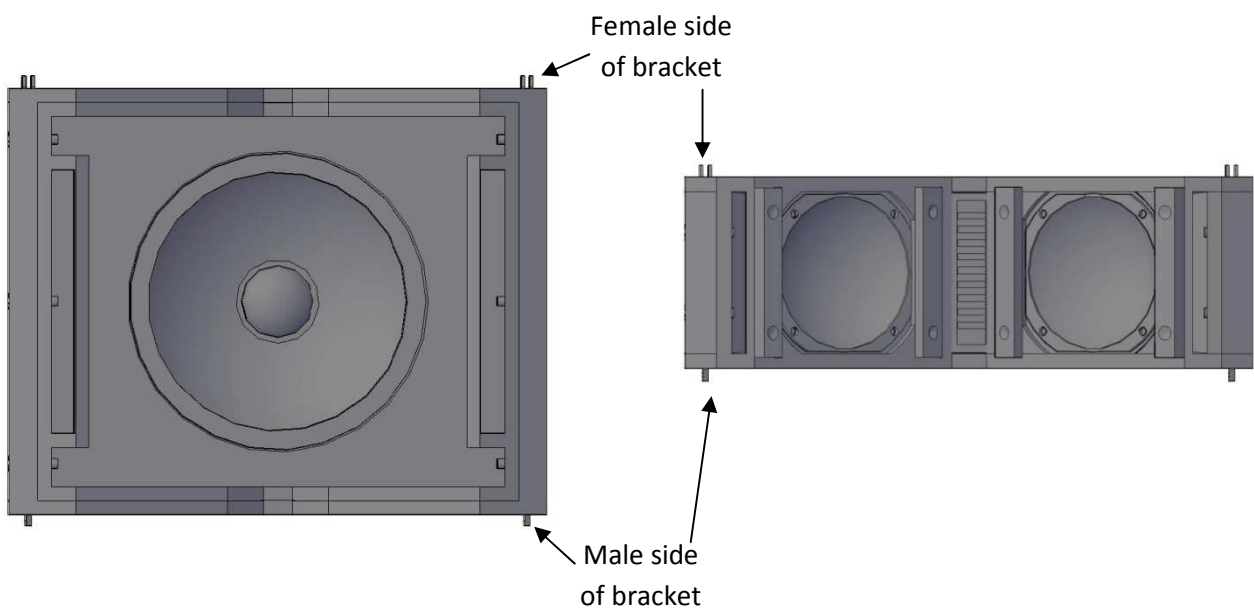

Overlap the speakers aligning the rigging holes, then secure them with the quick release pins.

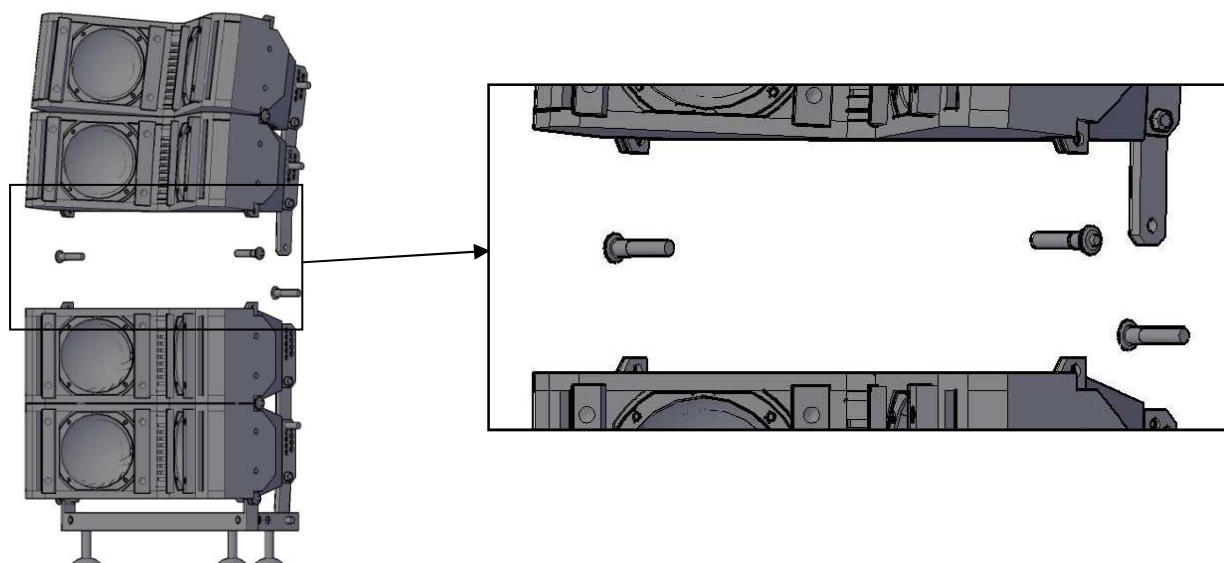

The bracket for the regulation of inclination is in the rear of the case.

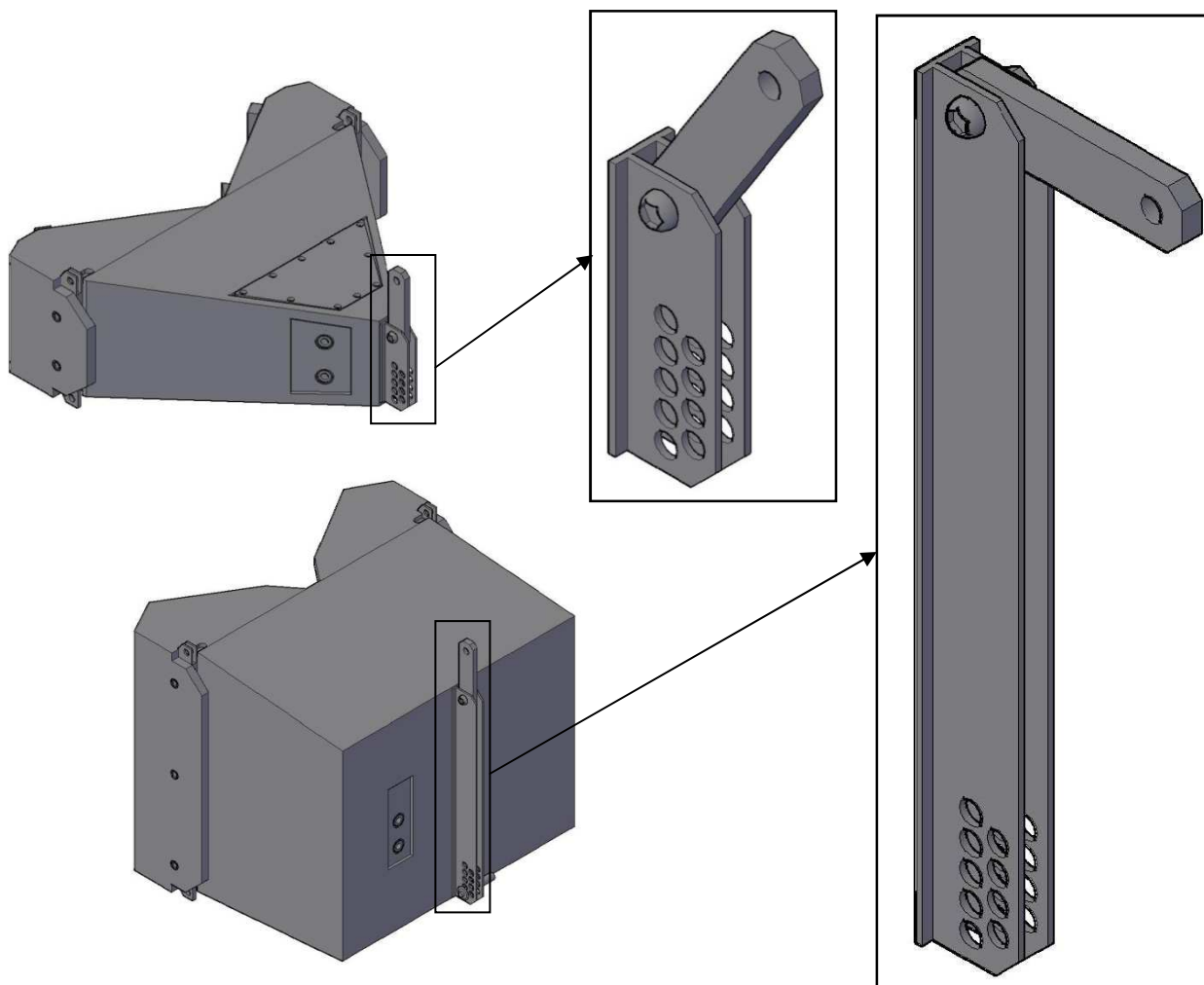

Rear brackets of two overlapping speakers must be connected via the connecting bracket. Align the holes in the desired position, then secure them with the quick release pins.

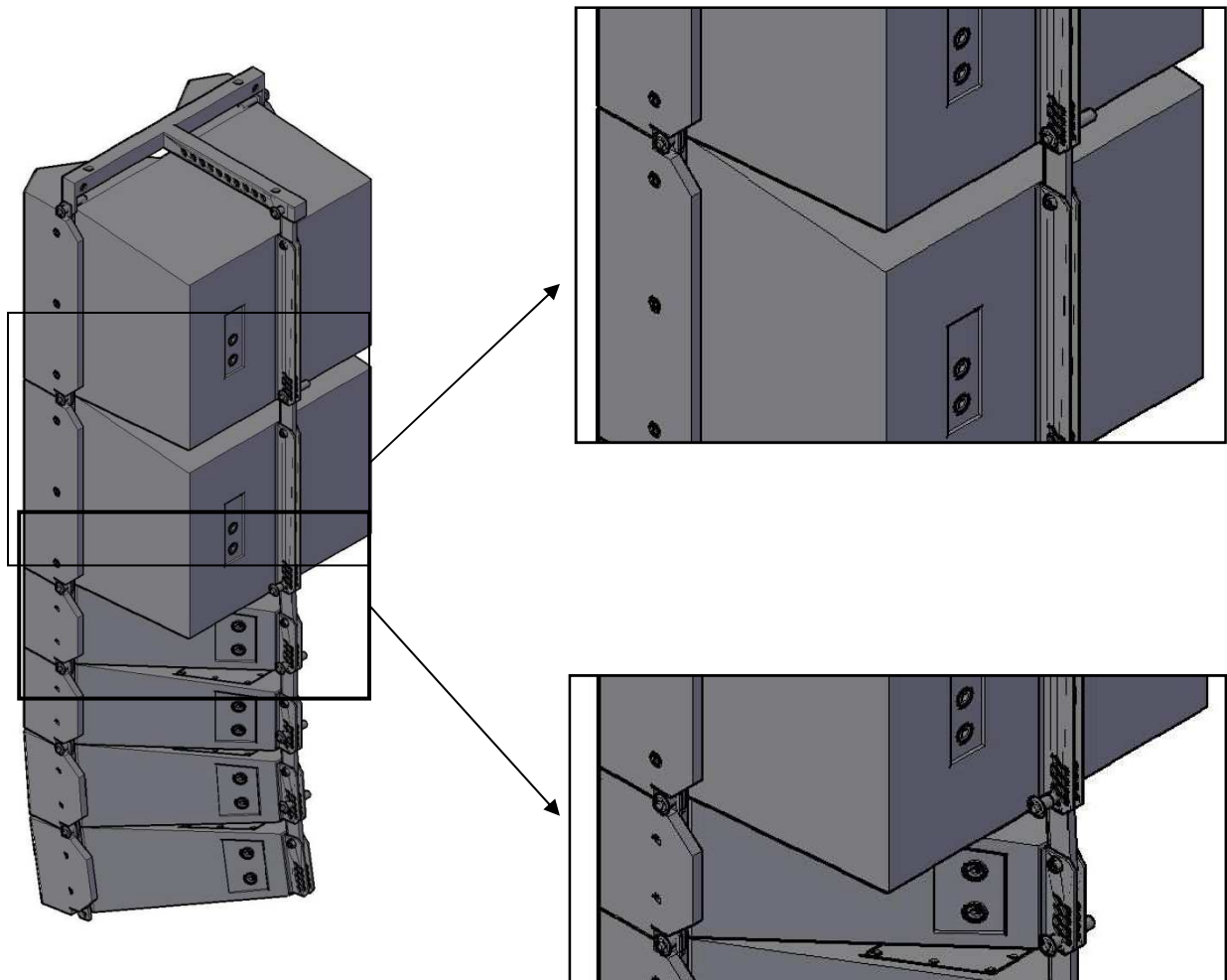
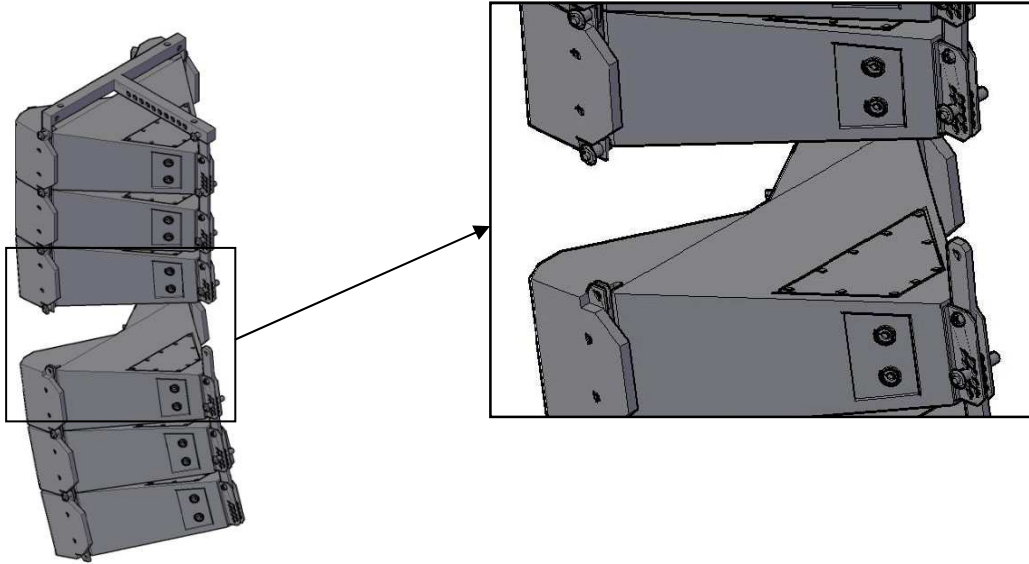

The regulation holes of the bracket allow to choose the desired inclination of the top speaker than the bottom speaker.

Value of the degrees of inclination for each hole are shown on the printed label on the plate: 0°-1.25°-2.5°-3.75°-5°-6.25°-7.5°-8.75°-10°.

### SB17 LABEL

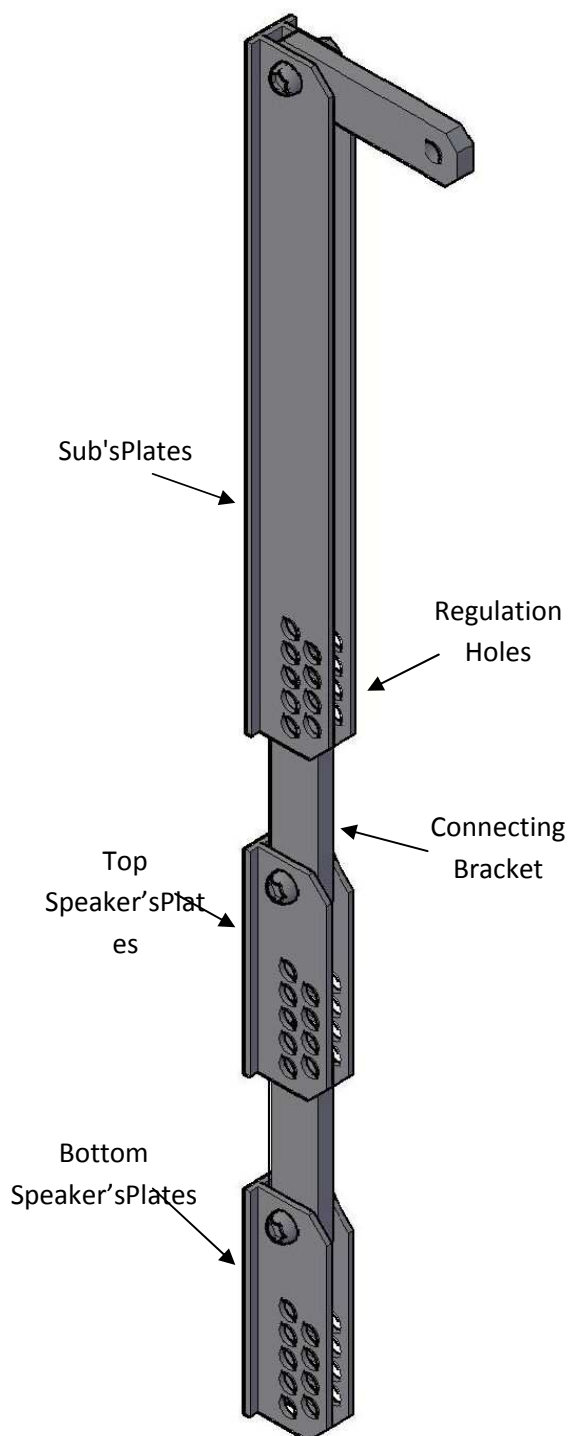
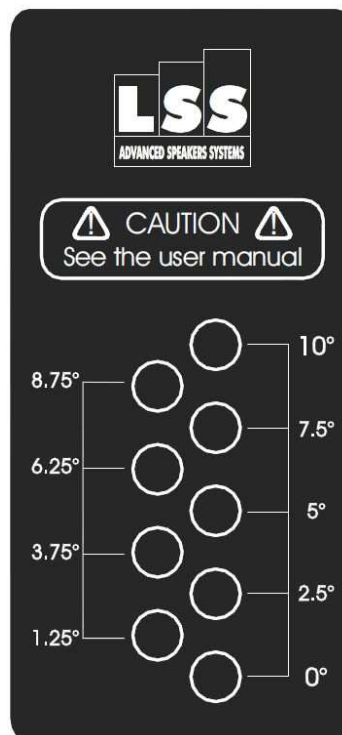

### ST17 LABEL

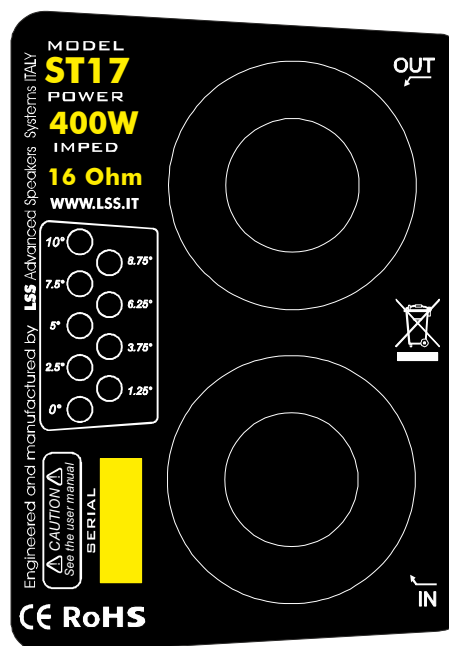

## INSTALLATION ON BUMPER

In both modes Stacking or Flying, it is necessary to use the dedicated hardware.

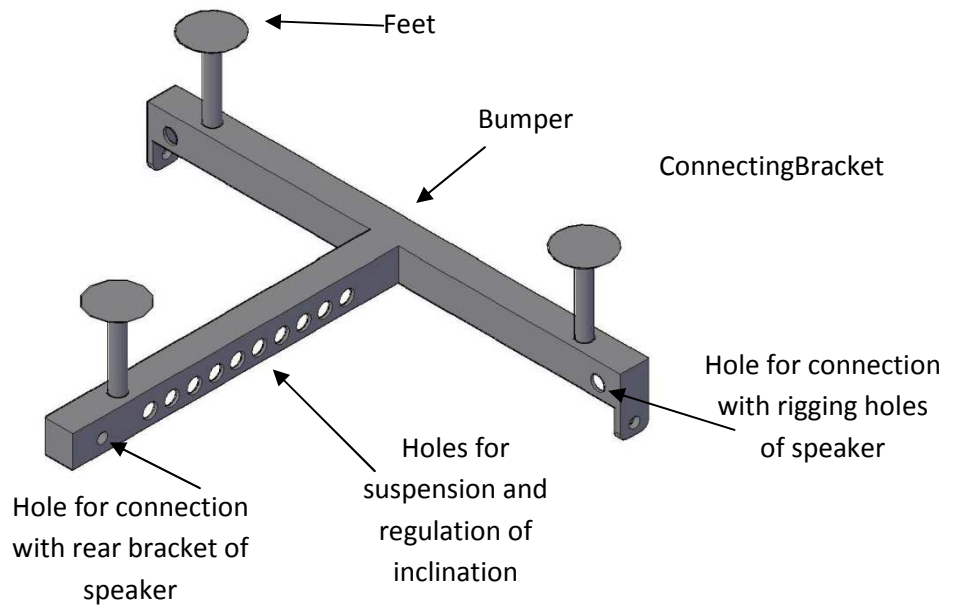

In case of installation in Stacking mode, install the feet and mount the speakers.

The fixing method of the first case to the bumper takes place in the same way of fastening between multiple speakers: attach the speaker to the sides via rigging holes, then connect the rear bracket adjusting the inclination.

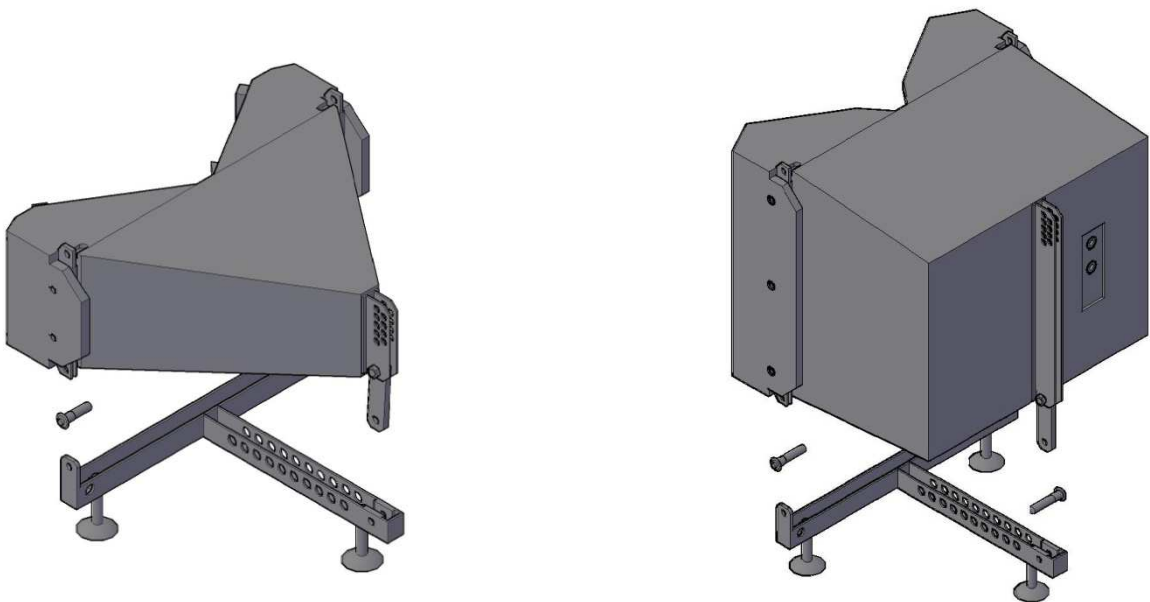

In case of installation in Flying mode, use the bumper without feet, attach the speaker to the sides via rigging holes, then connect the rear bracket adjusting the inclination.

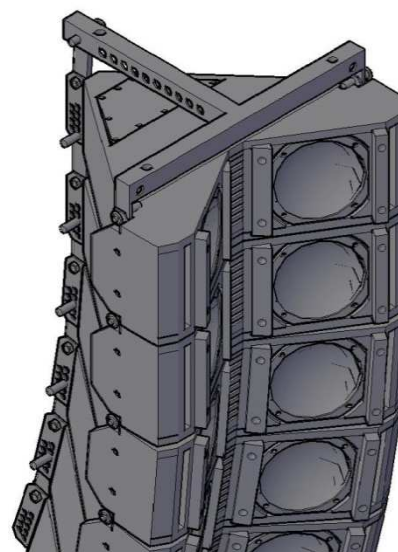
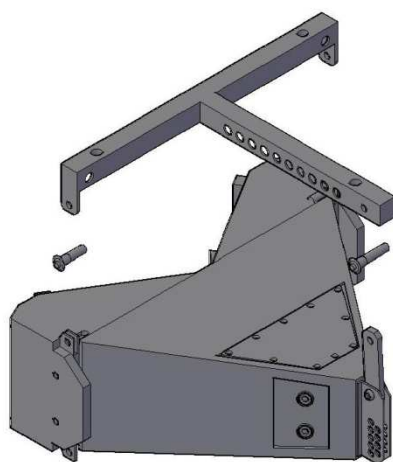

## BUMPER AND SYSTEM HANGING

Bumper can be fixed to the ceiling or other supports via holes for bumper suspension or the holes for suspension and regulation of inclination using eyebolts and a chain or a rope able to support the weight of the entire apparatus.

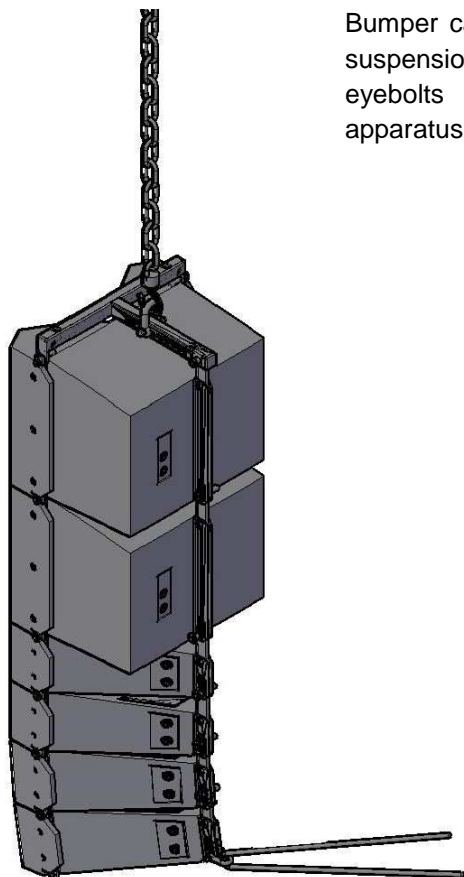

Suspending the bumper from holes for suspension and regulation of inclination, it is possible to determine the inclination of the entire system. Inclination value depends from hole and speakers used because of varying the number of speakers, change the center of gravity, so for an exact operation use an inclinometer.

To pull back the system, connect an eyebolt to the rear speaker plates and a rope or a chain, then manage the inclination.

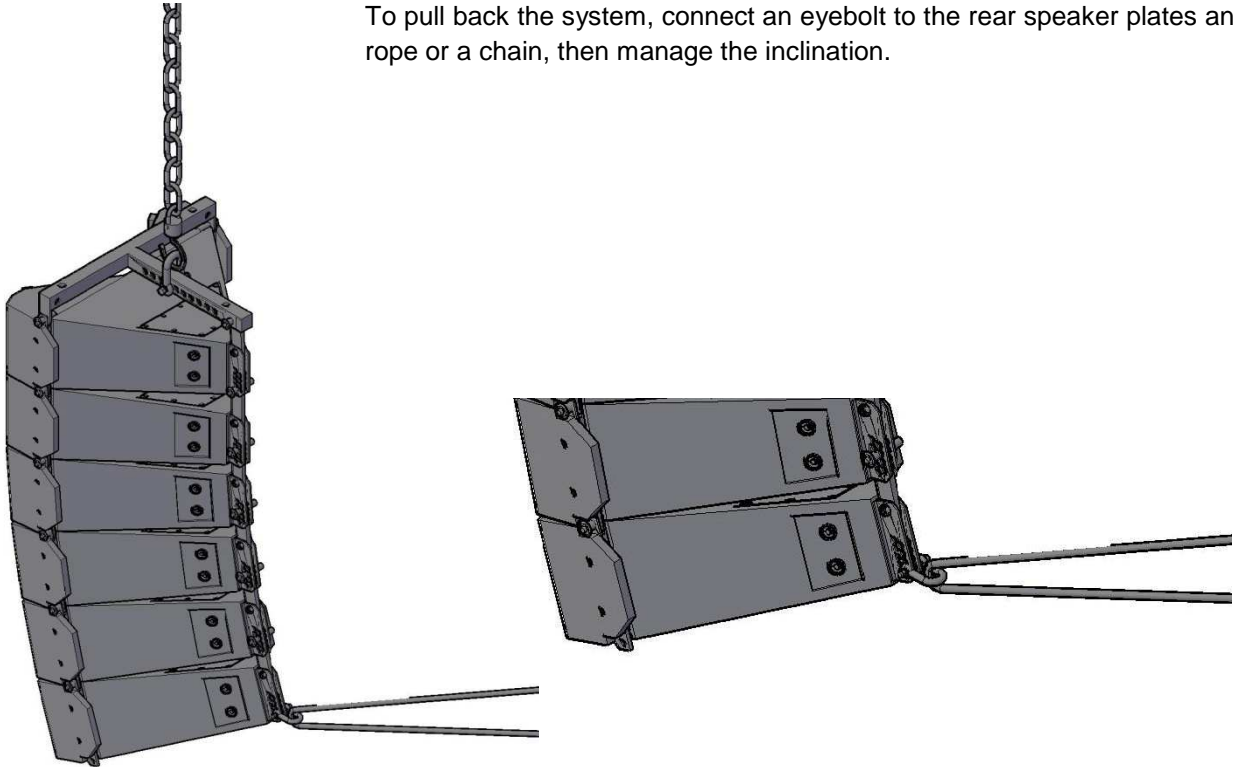

## ARRAY SIMULATOR SOFTWARE

The angle of tilt of the single speaker, as well as the inclination of the entire system depends on the location of installation and the listening audience.

To know exactly these angles for optimal installation, equip with an inclinometer and use the software 'Array Simulator'\* of LSS.

After inserting the information of the speakers system and installation location, 'Array Simulator' software\* allows to:

- Display of pointing and layer maps.
- Display the structure of the hanging system .
- Print complete reports.
- Display levels on the areas of listening.
- Calculation of the angle of inclination to the chosen point of suspension.
- Preset for the areas of listening and the setup of the array.
- Display Pressure Levels (SPL).

.....



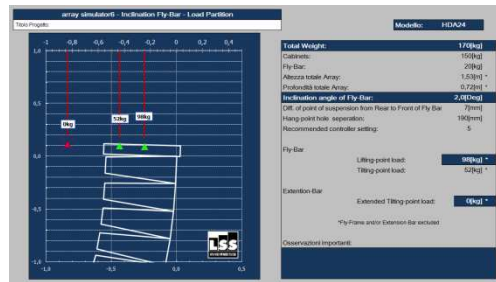
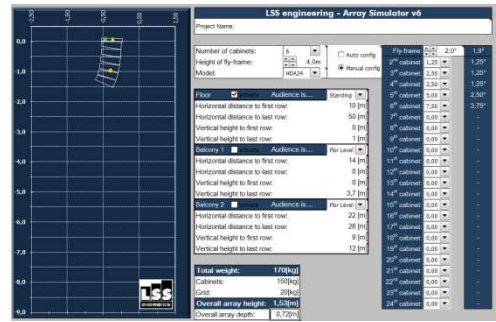
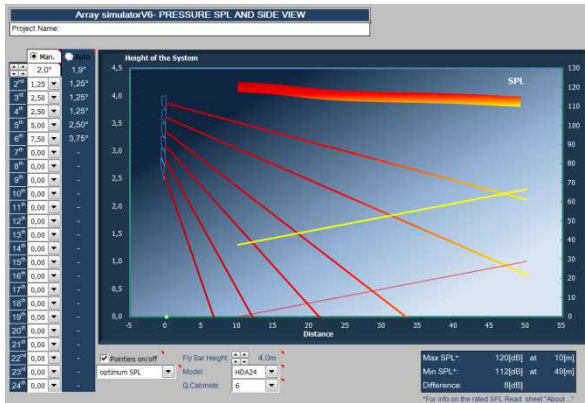

\*To receive the software or to have more information, contact your LSS distributors or send an email to tech@lss.it.

## INSTALLATION ON A POLE

To install the speakers on a pole, it is necessary to use the dedicated hardware: bumper and pole mount cup.

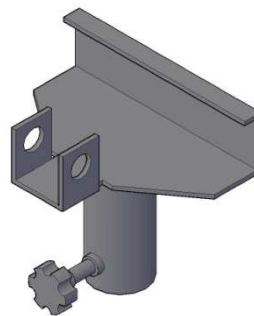

Install the bumper on the pole mount cup, then secure them with the quick release pins.

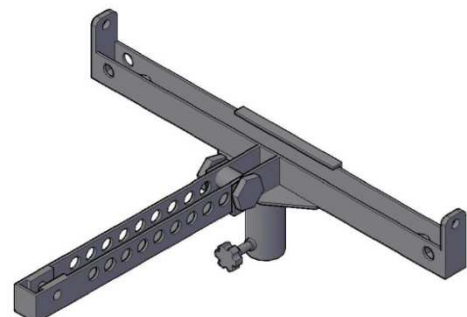
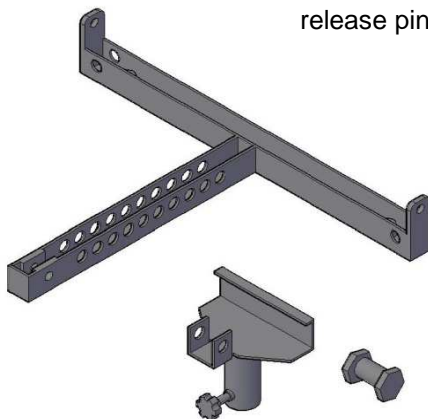

## TRANSPORT OF SPEAKERS

If you need to move the speakers it is possible to use a flight case on wheels. It may contain up to two SB17.



## ELECTRICAL CONNECTION

In the connection panel there are two Speakon NL4 connectors referred as 'IN' and 'OUT'.

IN is the input connector and must be connected to the amplifier, 'OUT' can be used to connected other systems.

Woofer of SB17 is connected on pins 1+ 1-.

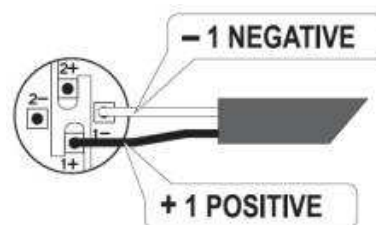
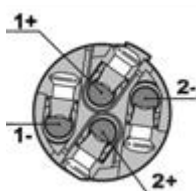
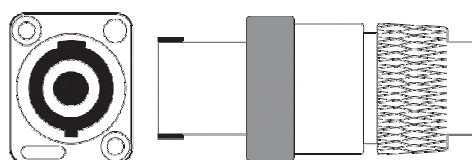
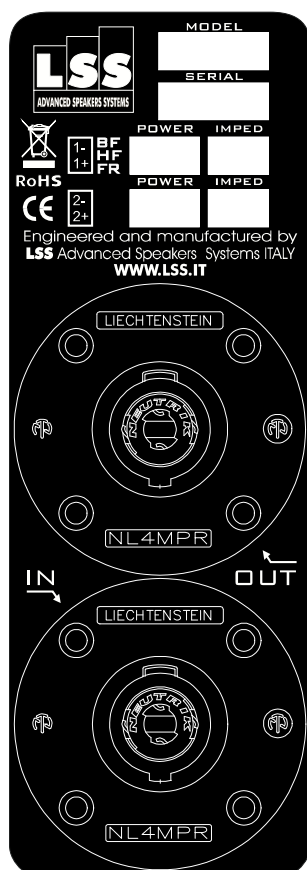

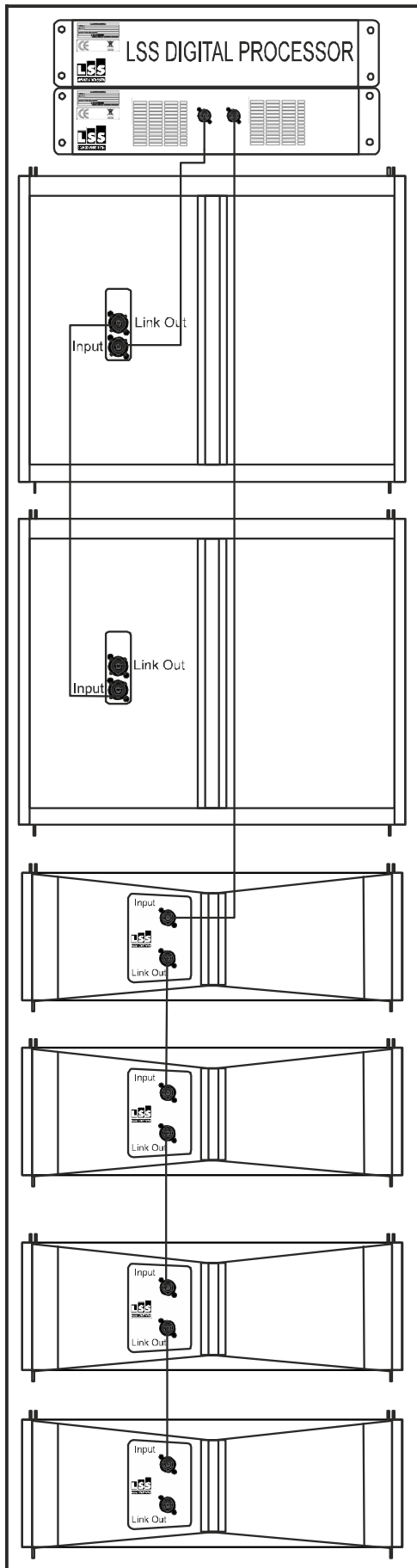

To use an array with ST17 and SB17 is necessary an external digital processor with custom setup provided by LSS. One output channel drive the SB17 and another one drive the ST17. If your amplifier can manage a 2 Ohms Load and has sufficient power, it is possible to connect a maximum of 6 ST17 in parallel per channel (total impedance will be 2 Ohms) or 4 SB17 in parallel per channel

Choose a safe mounting location, so as to prevent the cables can be stepped on or create tripping hazards.

Before making connections between mixer and speakers, make sure the mixer volume is turned down.

You can now use the system.

## WEEE DIRECTIVE

### WEEE Directive

#### Warning!

The product is marked with this symbol which indicates not to discard electrical and electronic equipment via the normal procedure for disposal of household waste. For these products there is a diverse collection system in accordance with legislation that requires proper treatment, recovery and recycling of used products. For more information please contact the appropriate local authority.

The black bar underneath indicates that the product was placed on the market after 13 August 2005.

#### INFORMATION FOR PROPER DISPOSAL

##### For home users

##### In the European Union

Warning: To dispose of this equipment, do not use the ordinary dust bin!

The electrical and electronic equipment must be treated separately and in accordance with legislation that requires proper treatment, recovery and recycling of used products. Following the implementation by member states, private households within the EU can give free electrical and electronic equipment to designated collection facilities \*.

In some countries (\*), your local retailer may withdraw the old product for free if you purchase a new one of similar type.

\* For more information please contact the appropriate local authority.

**In countries outside the EU:** please contact your local authorities and ask for the correct method of disposal.

**In Switzerland:** Used electrical or electronic equipment can be returned free of charge to the dealer, even if you do not purchase a new product.

Further collection facilities are listed on the homepage or [www.swico.ch](http://www.swico.ch).  
[www.sens.ch](http://www.sens.ch).

##### For professional users

##### In the European Union

Warning: If the product is used for business purposes, the following steps to delete it:

contact your LSS dealer for information about the product recall.

Might be charged for the costs of collection and recycling. Small products (and amounts) might be taken back by your local collection facilities.

**In Spain:** contact the established collection system or the local authority for collection of used products.

**In countries outside the EU:** please contact your local authorities and ask for the correct method of disposal.



## DIMENSIONS

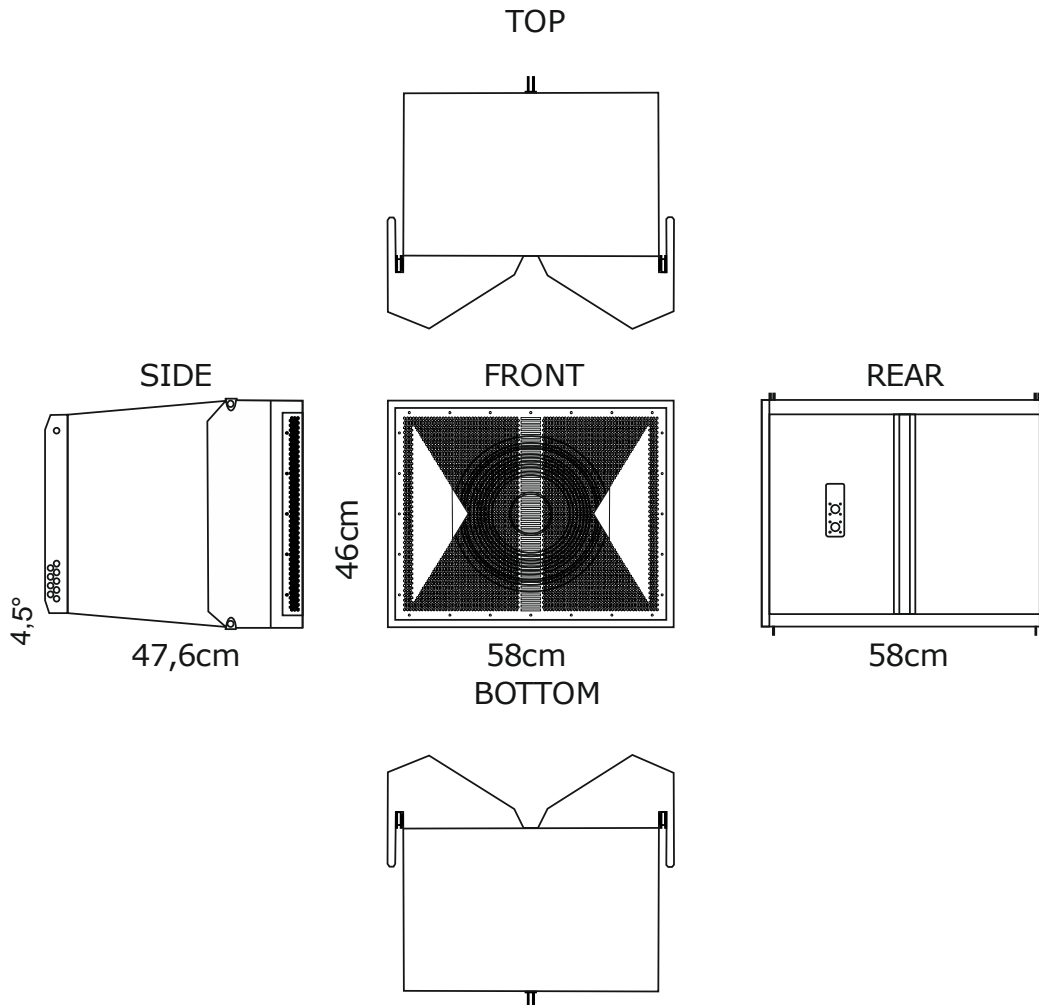

---

## NOTES



**CONTACT INFORMATION:**

**LSS Advanced Speaker Systems**

Via On. Longo 53  
89024 Polistena (RC) ITALY  
Tel (39) 966 9321299 – Fax (39) 966 933007  
Email: [info@lss.it](mailto:info@lss.it) - Internet: [www.lss.it](http://www.lss.it)